

The 1967 - 1970 390, 427, and 428 had their own unique motor mount setup.

Even the transmission crossmember was different. The 390/427/428 with manual transmission had a unique mount, which appeared to be the same as the standard part, but was in fact deeper, mounting the transmission lower than the standard unit. The C6 automatic cars had a unique 3-point crossmember, to provide clearance for the large valve body on the C6 case.

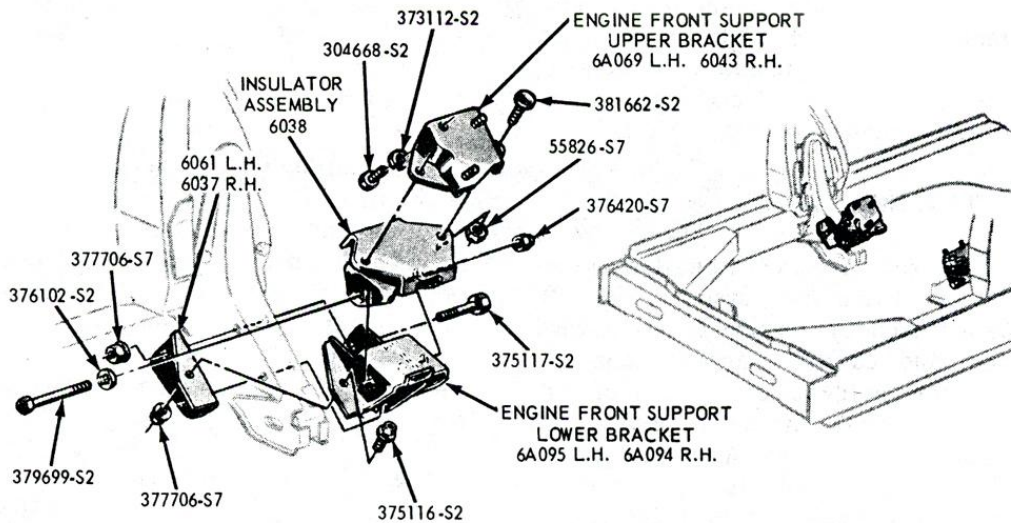

Engine Front Supports—Mustang and Cougar With 390 or 427 V-8

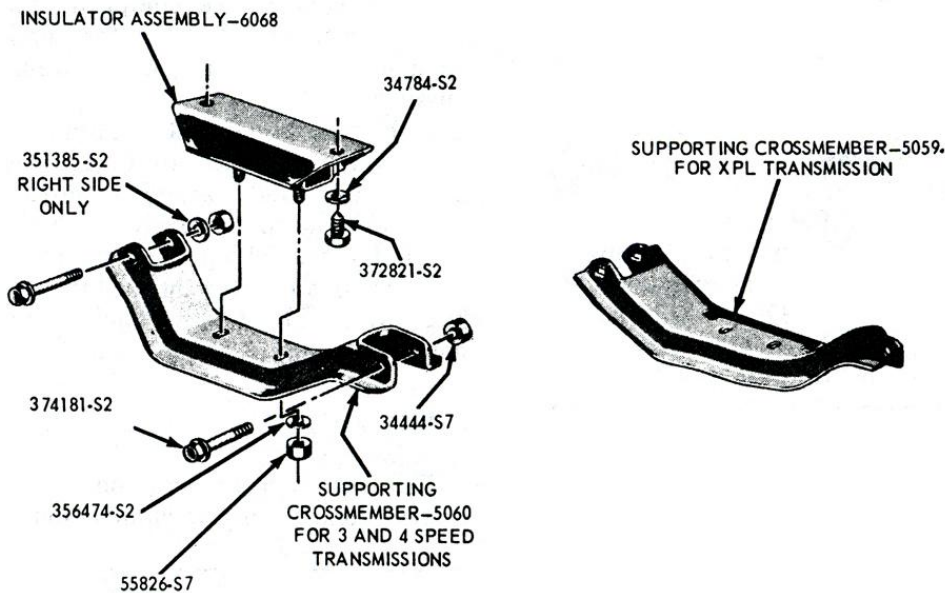

Engine Rear Support—Mustang and Cougar With 390 or 427 V-8

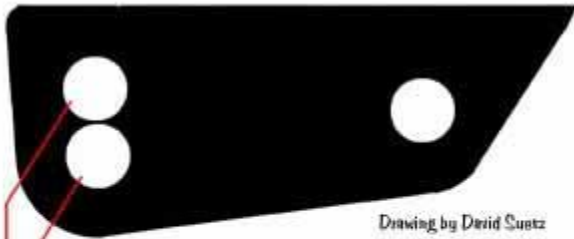

Drawing by David Suetz

66 all, 68 289 except convertible, 68-70 302 except convertible,
69 BOSS 302, 69-70 351 except convertible

67 289 all, 68 289 convertible, 68-70 302, 351
convertible, 70 BOSS, 67-70 390, 428